

# QUANTUM



**CURBTENDER**  
[www.curbtender.com](http://www.curbtender.com)



# QUANTUM

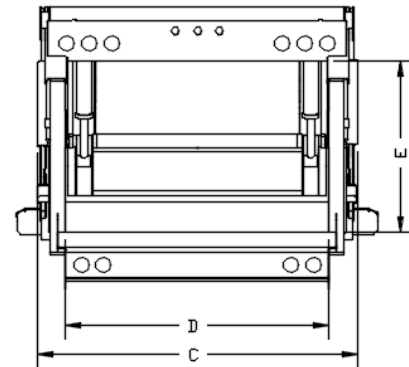
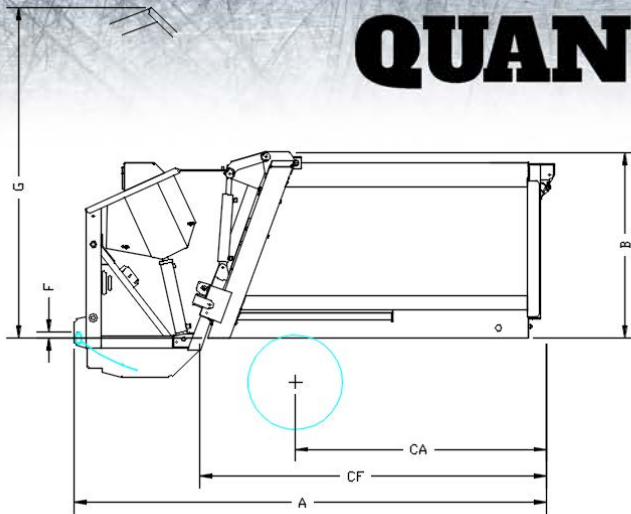

## Body Specifications

	6 CU. YD.	8 CU. YD.	10 CU. YD.
A: LENGTH OF BODY	158"	182"	200"
B: HEIGHT OF BODY ABOVE CHASSIS	62"	62"	62"
C: BODY WIDTH	83"	83"	83"
D: HOPPER OPENING WIDTH	70"	70"	70"
E: HOPPER OPENING HEIGHT	45"	45"	45"
F: LOADING SILL ABOVE CHASSIS FRAME	2"	2"	2"
G: HEIGHT OF TAILGATE ABOVE CHASSIS FRAME (TAILGATE RAISED)	110"	110"	110"
HOPPER CAPACITY	1 CU. YD.	1 CU. YD.	1 CU. YD.
HOPPER CAPACITY W/CLD	1.1 CU. YD.	1.1 CU. YD.	1.1 CU. YD.
DYNAMIC HOPPER CAPACITY (CU. Y.D. /Min.)	4.5 CU. YD.	4.5 CU. YD.	4.5 CU. YD.
APPROX. BODY WEIGHT	5,520 LBS	5,920 LBS	6,020 LBS

## Minimum Chassis Recommendations

	17,500 LBS	19,500 LBS	21,000 LBS
MINIMUM GVWR	17,500 LBS	19,500 LBS	21,000 LBS
CA USABLE CAB TO AXLE	84"	108"	120"
CF MIN. TO END OF FRAME	116"	140"	152"
REQ'D CHASSIS FRAME HEIGHT	30" TO 36"	30" TO 36"	30" TO 36"

## Body Construction

- Roof: 11 gauge GR50
- Sides: 11 gauge GR50
- Floor: 11 gauge GR50
- Ejection Panel: 11 gauge GR50
- Sweep Face 3/16 GR100
- Tailgate side wall (upper): 11 gauge GR50
- Tailgate side wall (lower): 7 gauge GR50
- Tailgate Floor: 3/16 AR400

## Features

- High compaction rating
- Patented packing mechanism
- Pack cycle time of 13 seconds

- Receives commercial containers without use of a tailgate flare
- High strength "chiseled" body side walls
- Auto locking tailgate mechanism
- Rear Fenders standard
- Curved floor provides liquid sump
- Low body height
- Easy to maintain

## Hydraulics

- Oil Reservoir: 20 gal. (75.7 liters)
- Oil Flow w/ Standard Pump: 22 GPM
- Operating Pressure: 2,700 PSI
- Engine RPM: 1,300 RPM
- Hose Burst Ratio: 4 to 1
- Return Filter: 10 micron
- Pack Cylinders: 3.5" bore diameter
- Sweep Cylinders: 3.5" bore diameter

- Eject Cylinders
  - 6 cu. yd: 3.5" bore diameter, 2 stage telescopic
  - 8 cu. yd: 4.5" bore diameter, 3 stage telescopic
  - 10 cu. yd: 4.5" bore diameter, 3 stage telescopic
- Tailgate Lift: 3" bore diameter

## Optional Features

- Container roll bar with lip-and-latch
- Container lip-and-latch with 4,000 lb. drum winch
- Single cart tipper
- Cart tipper tap-in-kits
- Work lights & Strobe lights
- Broom and shovel holder
- Rear view color camera system
- Hopper bottom 3/16" AR400



**ASK ABOUT  
THE ALL-ELECTRIC  
QUANTUM!**

**CURBTENDER**

www.curbtender.com

701 PERFORMANCE DRIVE, CEDAR FALLS, IA 50613

PHONE: 319.266.1721, FAX: 319.266.8207

© 2017 Curbtender Inc., All Rights Reserved. Specifications subject to change.