

REVISIONS			
REV.	DESCRIPTION	DATE	APPROVED

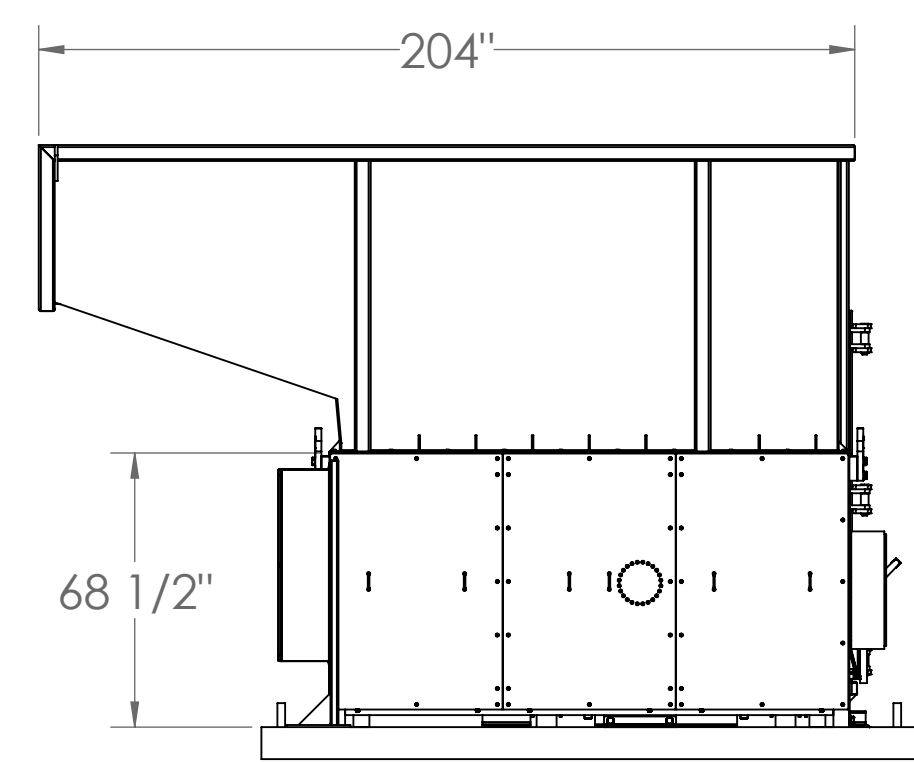
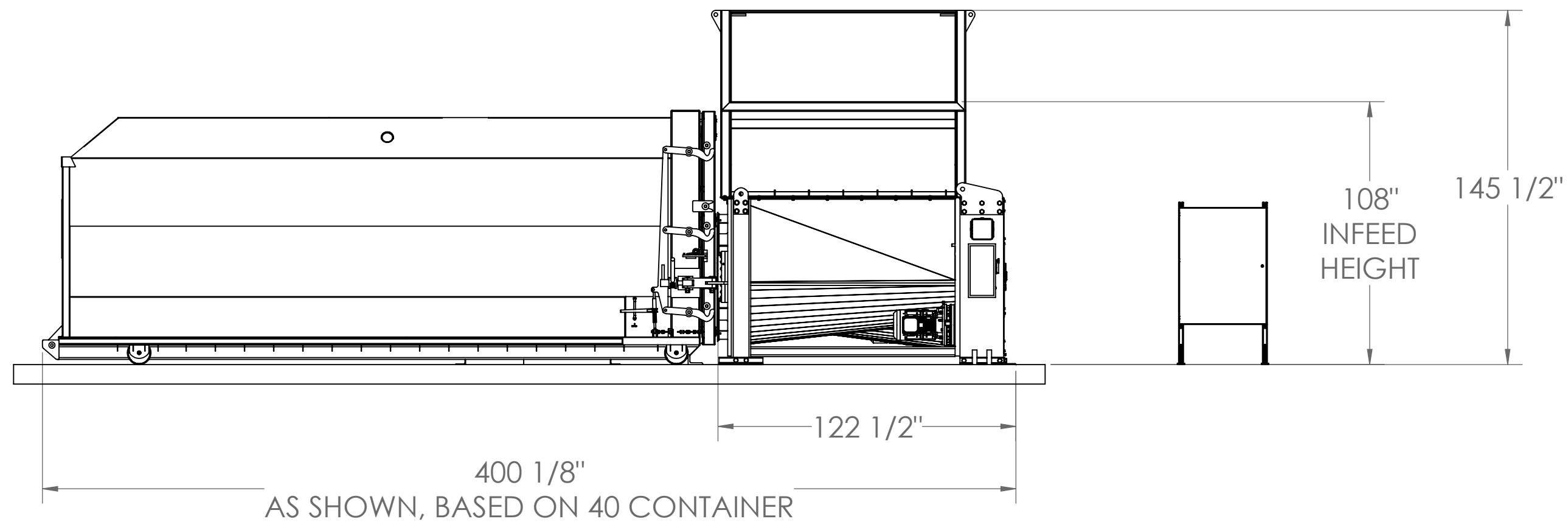
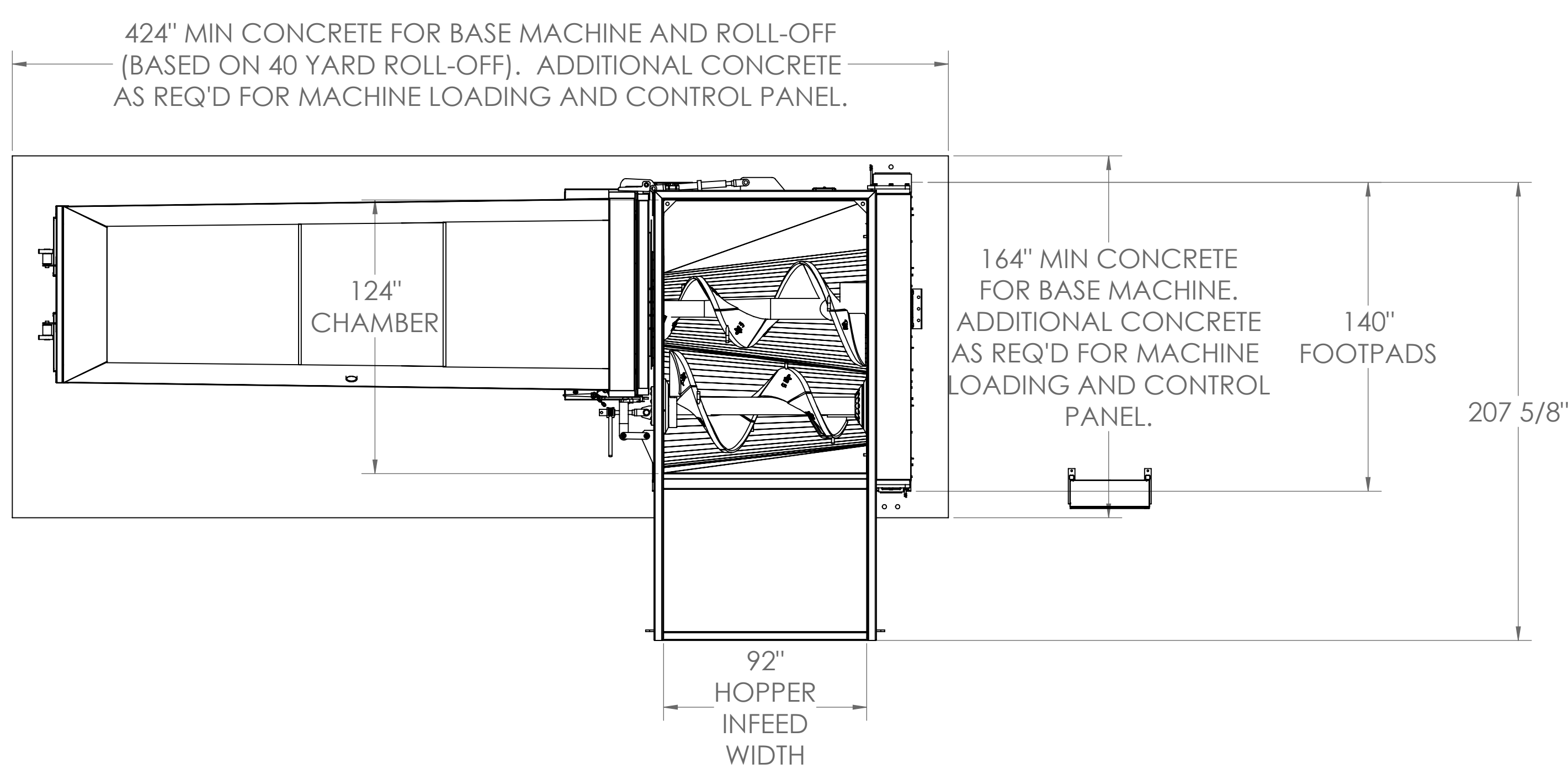
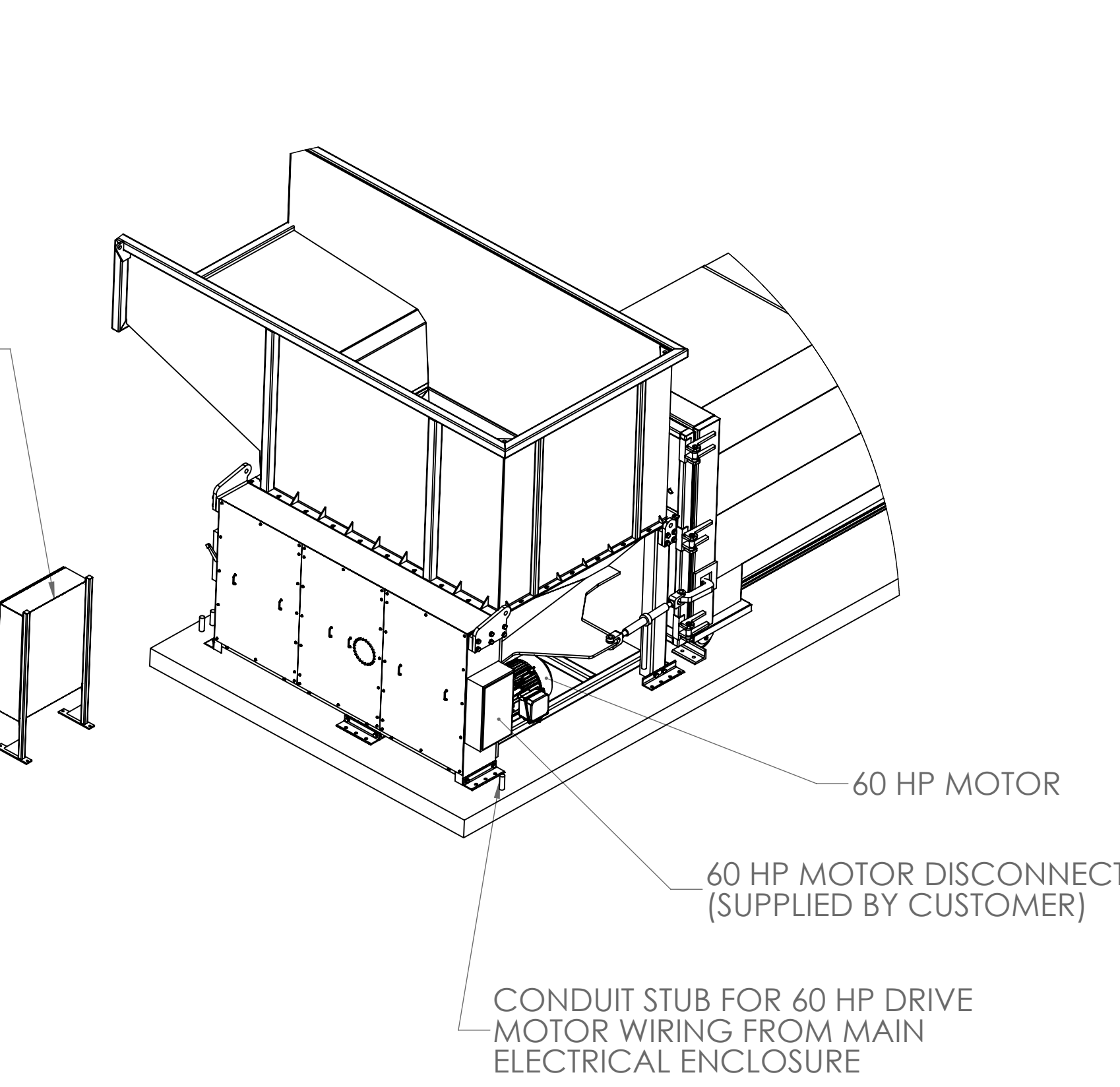
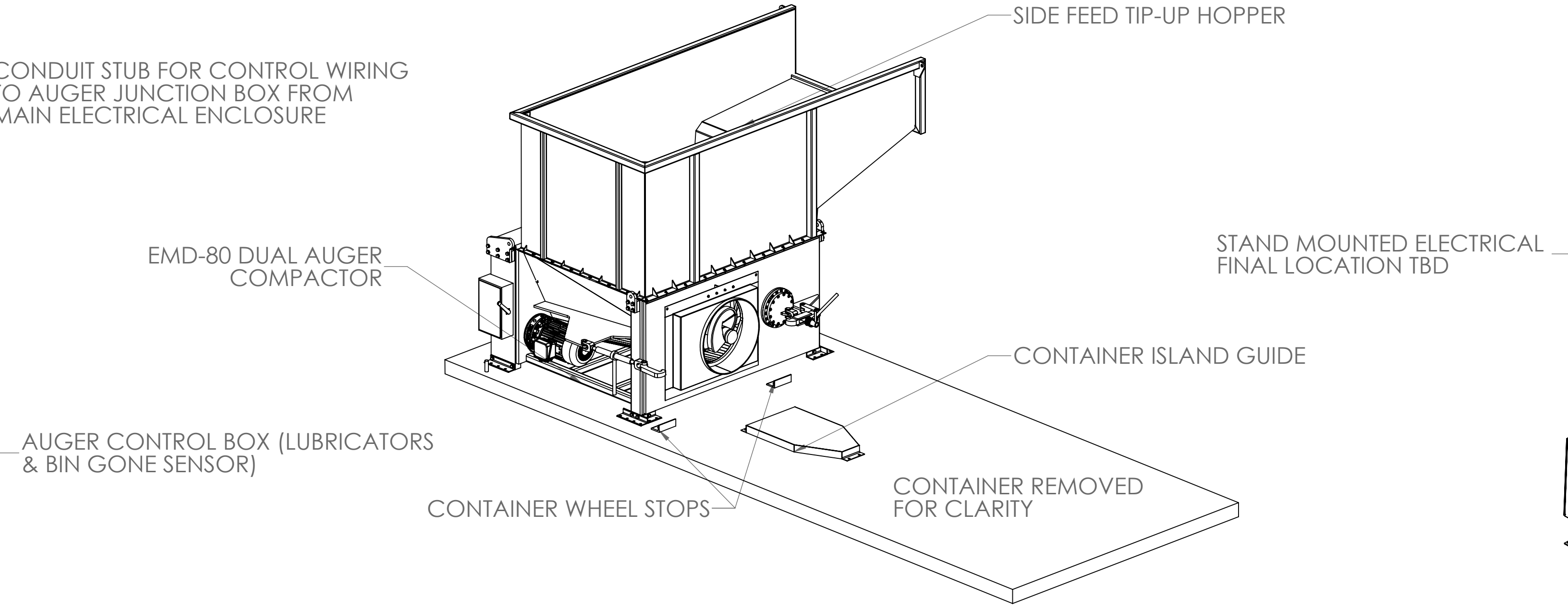
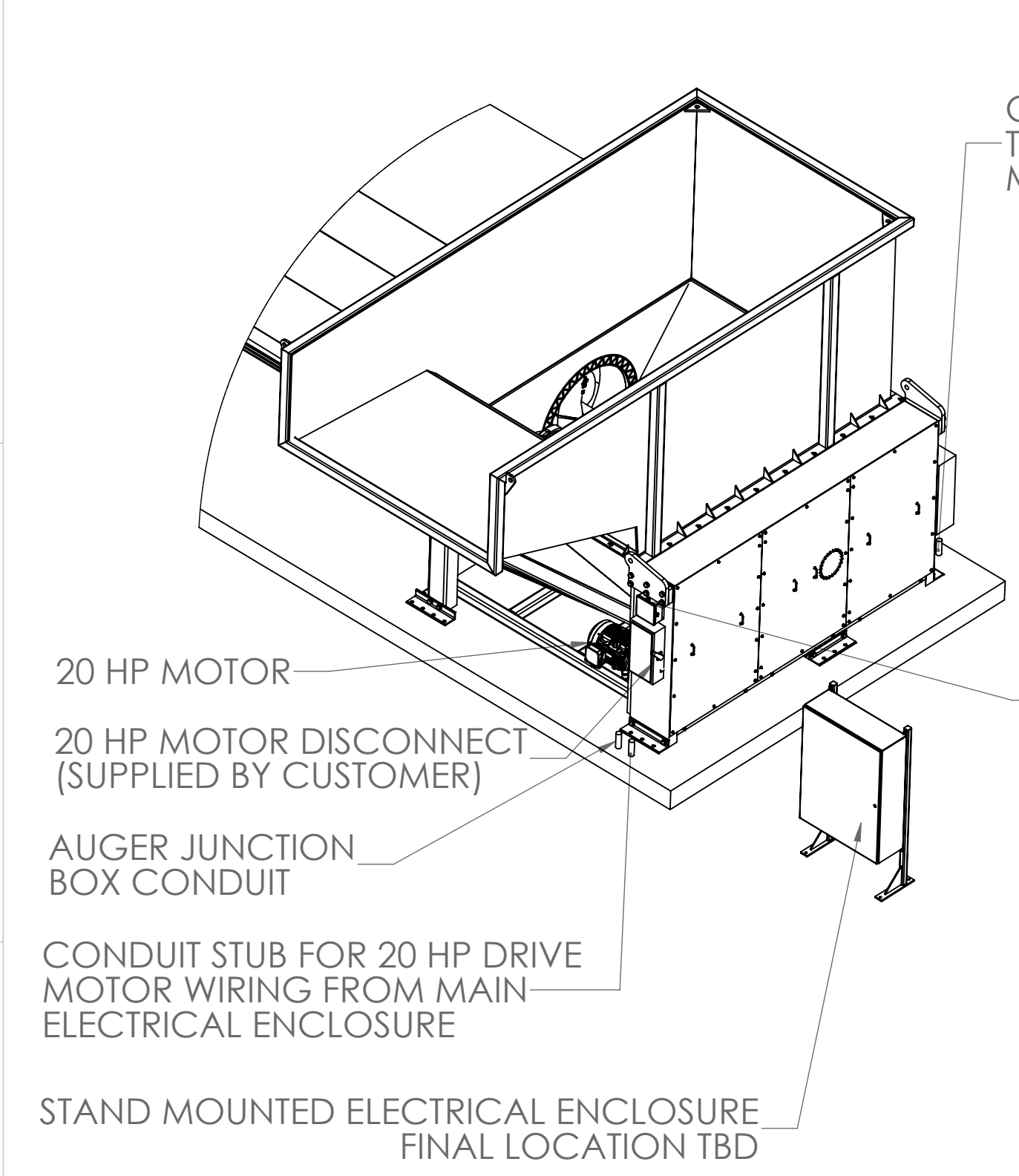

- GENERAL NOTES:**
1. POWER REQUIREMENTS: 480V, 3 PHASE, MINIMUM 200 AMP SERVICE REQUIRED. ELECTRICAL SERVICE MUST BE SUITABLE TO HANDLE THE INRUSH WHEN STARTING 20 AND 60 HP MOTORS.
 2. CONCRETE PAD: 6" - 8" MINIMUM CONCRETE PAD THICKNESS REQUIRED FOR MACHINE AND RECEIVING CONTAINER. CONCRETE PAD TO EXTEND 12" AROUND FOOTPRINT OF MACHINE AND RECEIVING CONTAINER

<p>PATENTS</p> <p>THE INFORMATION OPERATED ON THIS DRAWING MAY BE COVERED BY ANY ONE OR ALL OF THE FOLLOWING PATENTS:</p> <p>UNITED STATES</p> <p>4026163 09/15/03 09/08/04</p> <p>493884 09/30/09 03/08/02</p> <p>518046 02/17/11 03/08/02</p> <p>CANADA AUSTRALIA DENMARK</p> <p>1129386 01/02/02 02/07/10 09/02/09</p> <p>02002 02/02/02</p> <p>0309793</p> <p>OTHER U.S. AND FOREIGN PATENTS ISSUED AND PENDING</p>	<p>PROPRIETARY AND CONFIDENTIAL</p> <p>THIS DRAWING CONTAINS CONFIDENTIAL INFORMATION AND IS THE EXCLUSIVE PROPERTY OF KOMAR INDUSTRIES, INC. NEITHER THE DOCUMENT NOR ITS CONTENTS ARE TO BE USED, REPRODUCED, OR DISCLOSED IN WHOLE OR IN PART, WITHOUT THE WRITTEN PERMISSION OF KOMAR INDUSTRIES, INC.</p> <p>DO NOT SCALE DRAWING</p>	<p>UNLESS OTHERWISE SPECIFIED:</p> <p>DIMENSIONS ARE IN INCHES</p> <p>TOLERANCES</p> <p>FRACTIONAL: ± 1/16</p> <p>ANGULAR: MAX ± 1°</p> <p>HOLES: +.003 / -.002</p> <p>TWO PLACE DECIMAL: ± .01</p> <p>THREE PLACE DECIMAL: ± .005</p> <p>INTERPRET GEOMETRIC TOLERANCING PER:</p> <p>ASME Y14.5-2009</p> <p>FINISH</p> <p>STOCK SIZE</p>	<p>NAME</p> <p>MRL</p> <p>DATE</p> <p>3/1/2018</p>	<p>DRAWN</p> <p>CHECKED</p> <p>ENG APPR.</p> <p>IMG APPR.</p> <p>G.A.</p> <p>COMMENTS:</p>	<p>Komar</p> <p>INDUSTRIES, INC.</p> <p>4425 MARKETING PLACE, GROVEPORT, OH 43125 U.S.A (614) 699-2366</p>		
			<p>FILE NO.</p> <p>GA3939-001</p>	<p>REV</p> <p>1</p>	<p>Configuration Part Num: Default</p> <p>SIZE File / DWG. NO.</p> <p>D GA3939-001</p> <p>SCALE: 1:96/WEIGHT:</p>	<p>TITLE</p> <p>EMD-80 W/TIP-UP SIDE FEED HOPPER</p>	<p>SHEET 1 OF 1</p>