

FEATURE	DESCRIPTION	SPECIFICATION
Capacity	Tilt Out Bag Cage	12-1/2 cu.ft. 95 US Gallons (360L)
	Poly Bag	2.5 mil 30 x 38 (760 x 965)
	Optional Canvas Bag	Reusable
	Optional Poly Liner	25 US Gallons (95L)
Construction	Housing	14 Ga. (1.9) Galvanneal Steel
	Lid	14 Ga. (1.9) Galvanneal Steel
	User Door	14 Ga. (1.9) Galvanneal Steel
	Side Hinged Unloading Door	14 Ga. (1.9) Galvanneal Steel
	Hinges and Latches	Stainless Steel
	Paint	Powder Coat
Weights	Standard Mini Hid-A-Bag III	320lbs (145kg)
	(Optional) Pre-Cast Mounting Pad (HBG-3738)	600lbs (272kg) 60 x 32 x 4 (1525 x 815 x 102)

ALL SPECIFICATIONS SUBJECT TO CHANGE WITHOUT NOTICE

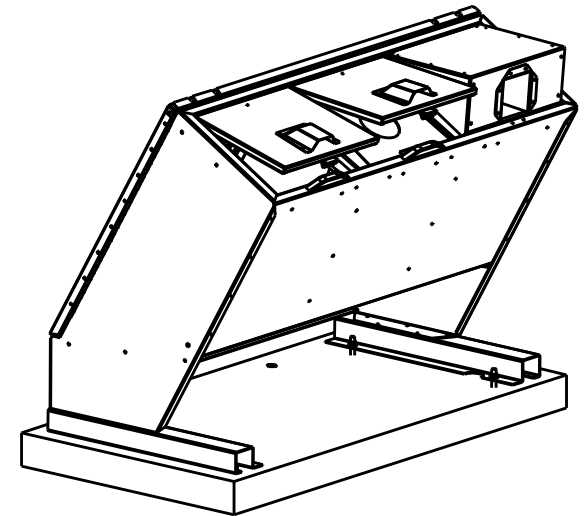
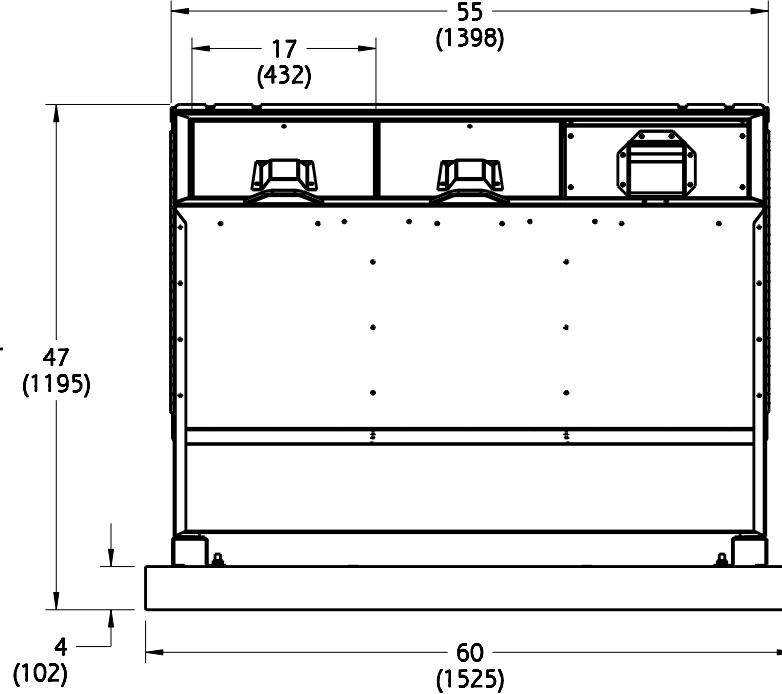
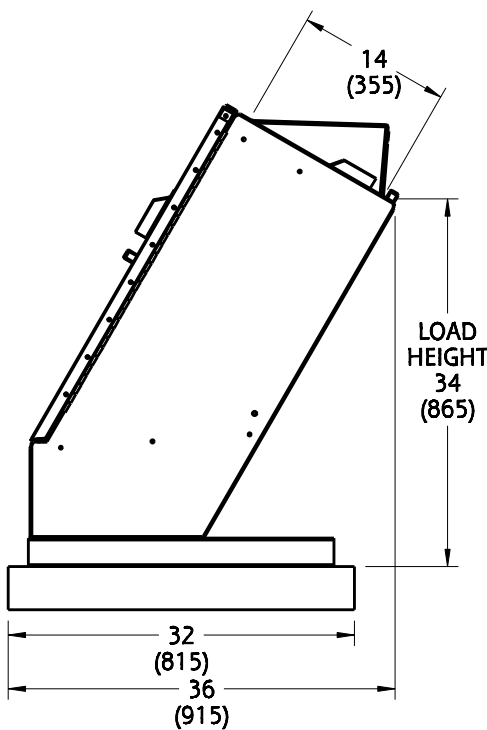
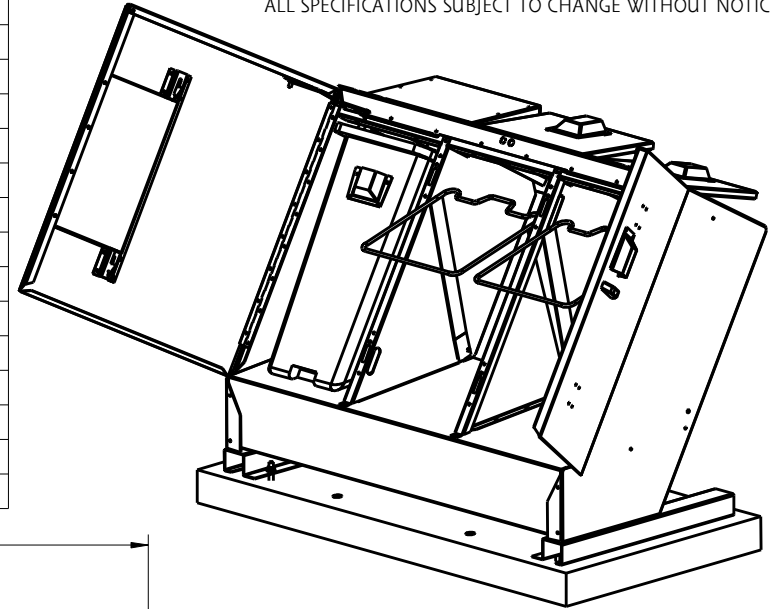

NOTE: ALL DIMENSIONS INCHES (MILLIMETERS)

TRAILER SIZE	QTY
8-1/2ft x 45ft	21
8-1/2ft x 53ft	30
B-Train 8-1/2ft x 28ft & 32ft	33
Double Decker Van 8-1/2ft x 48ft	54

HAUL-ALL EQUIPMENT LTD. reserves proprietary rights on this drawing or any part of the information contained thereon. This drawing shall be considered confidential material and is not to be used for competitive bidding nor for use in any procurements other than from Haul-All Equipment Ltd.



NAME HB3M RECYCLE CONTAINER	
PART NUMBER SP-HB3M	DRAWN BY PN
DATE JUNE 29, 2016	REVISION 1